



Solar Heat Exchange Manufacturing

Solar Made Simple

SHEM32 Solar System Controller

Operation Instructions

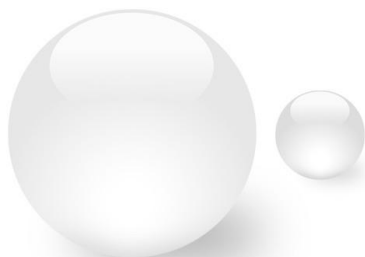

⚠ Please read this manual carefully before using the controller

Contents

Contents -----	1
1. Safety information -----	3
1.1 Installation and commissioning -----	3
1.2 About this manual -----	3
1.3 Liability waiver -----	3
1.4 Important remark-----	4
1.5 Description of symbols-----	4
1.6 Description of operation buttons-----	4
2. Installation -----	5
2.1 Installing the controller-----	5
2.2 Power connection -----	6
2.3 Terminal connections-----	6
3. Commissioning -----	8
3.1 Set time-----	8
3.2 SCH system selection -----	9
3.3 Menu structure-----	10
3.4 Menu description-----	11
3.5 System description-----	12
4. Controller functions -----	14
4.1 Access main menu -----	14
4.2 Access submenu -----	14
4.3 Main menu DT O & DT F Temperature difference functions-----	14
4.4 TEMP Temperature main menu-----	16
4.4.1 EM Emergency collector temperature (emergency switch-off temperature of collector) -----	17
4.4.2 CMX Maximum collector temperature (collector cooling function)-----	18
4.4.3 CMN low temperature protection of collector-----	19
4.4.4 CFR frost protection of collector -----	20
4.4.5 SMX Maximum tank temperature-----	20
4.4.6 REC Tank re-cooling function-----	21
4.4.7 C-F Celsius and Fahrenheit temperature -----	22
4.5 HND Manual pump mode-----	22
4.6 PASS Password setting-----	23
4.7 LOAD Recover factory settings -----	24
4.8 Temperature query function-----	24

4.9 "ON/OFF " Function-----	24
5. Protection function -----	24
5.1 Memory Protection-----	24
5.2 Screen protection-----	24
6. Troubleshooting-----	25
6.1 Protection -----	25
6.2 Trouble checking -----	25
7. Quality Guarantee -----	27
8. Technical data -----	28
9. Parts List-----	28
10. Accessories-----	29

Safety information

1.1 Installation and commissioning

- When installing cables, please ensure that no damage occurs to any of the building's fire safety measures.
- The controller must not be installed in rooms where flammable gases are present or may occur.
- The permissible environmental conditions can't be exceeded at the site of installation.
- Before connecting the device, make sure that the power supply matches the specifications that the controller requires.
- All devices connected to the controller must conform to the technical specifications of the controller.
- Unplug the power cord before removing the cover plate for servicing. All safety regulations for working on the power supply should be followed.
- Connecting and/or all operations that require opening the controller (e.g. changing the fuse) are only to be conducted by a professional.

1.2 About this manual

This manual describes the installation, function and operation of a solar thermal controller.

When installing the remaining components e.g. the solar collectors, pump assemblies and the storage unit, be sure to observe the appropriate installation instructions provided by each manufacturer. Only trained professional personnel may perform installation, electrical connection, commissioning and maintenance of the device. The professional personnel must be familiar with this manual and follow the instructions contained herein.

1.3 Liability waiver

The manufacturer cannot monitor the compliance with these instructions or the circumstances and methods used for installation, operation, utilization and maintenance of this controller. Improper installation can cause damages to material and persons. This is the reason why we do not take responsibility and liability for losses, damages or costs that might arise due to improper installation, operation or wrong utilization and maintenance or that which occurs in some connection with the aforementioned. Moreover we do not take over liability for patent infringements or

infringements occurring in connection with the use of this controller on third parties rights. The manufacturer preserves the right to make changes to the product, technical data or installation and operation instructions without prior notice. As soon as it becomes evident that safe operation is no longer possible (e.g. visible damage). Please immediately take the device out of operation. Note: ensure that the device cannot be accidentally placed into operation.

1.4 Important remark

We have carefully checked the text and pictures of this manual and provided the best of our knowledge and ideas, however inevitable errors may exist. Please note that we can not guarantee that this manual is given in the integrity of image and text. They are just some examples, and they apply only to our own systems. Incorrect, incomplete and erroneous information and the resulting damage we do not take responsibility for.

1.5 Description of symbols



Safety instructions:

The safety instructions in the manual are marked with a warning triangle.

They indicate measures, which can lead to personal injury and safety risks.

Operation steps: small triangle “▶” is used to indicate an operation step.

Note: Contains important information about operation or function.

1.6 Description of operation buttons

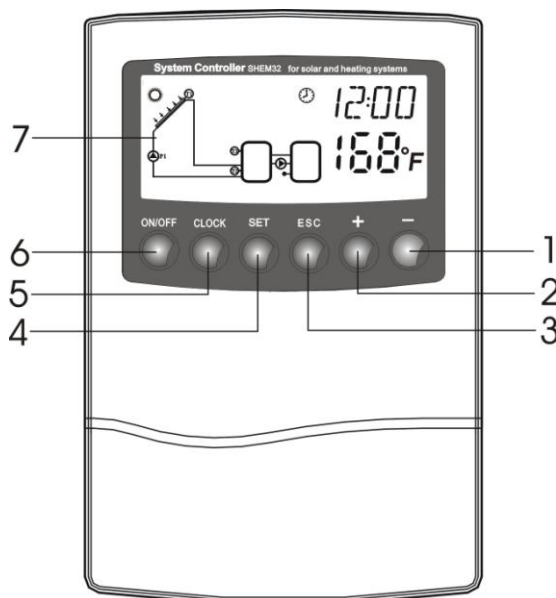

No.	Button description
1	"-" Parameter adjust button
2	"+" Parameter adjust button
3	"ESC", exit program setup
4	"SET" confirm button
5	"Clock" button
6	"ON/OFF" button
7	LCD display screen

2. Installation

Controller should only be installed indoors, far away from dangerous places and away from electromagnetic fields. Controller should be equipped with the power supply cord included in the package. If a replacement is necessary, use a 16AWGx3wire with a standard, grounded male plug. Plug the cord into a dedicated 110V receptacle. Do not use an extension cord, as this can be a fire and/or safety hazard.

2.1 Installing the controller



Note: the controller can only be installed in an area having an adequate level of protection.

Hanging the controller

- ▶ Choose a suitable site
- ▶ Mark the position of hole ①
- ▶ Drill a tap hole, insert screw ① leaving it sticking out 1/8"
- ▶ Remove the controller cover plate
- ▶ Hang the controller on screw ①
- ▶ Mark holes ② and ③
- ▶ Then remove the controller again.
- ▶ Drill holes for ② and ③ .
- ▶ Rehang the controller on screw ①
- ▶ Insert screws ② and ③ to fix in place

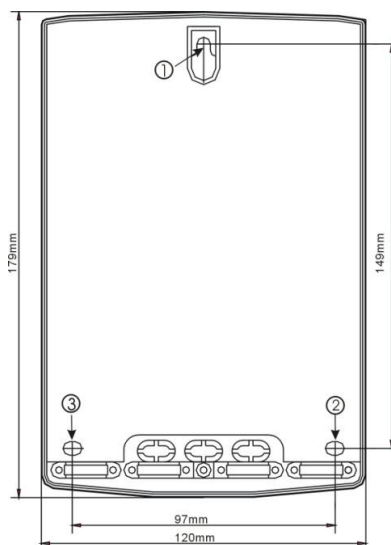

2.2 Power connection

Power should only be connected when the cover plate is closed. Make sure the cover plate is not damaged in order to keep out anything that could damage the electronics. Depending on the type of installation, the cables may enter the device through the rear holes of the case ④ or the lower side holes of the cover plate ⑤

If cables come from the rear ④: remove the plastic flaps from the rear side of the case using an appropriate tool.

If cables come from below ⑤: cut the left and right plastic flaps using an appropriate tool (e.g. knife) and break them out of the cover plate.

Note: The flexible wires must be fastened to the case using the strain relievers provided.

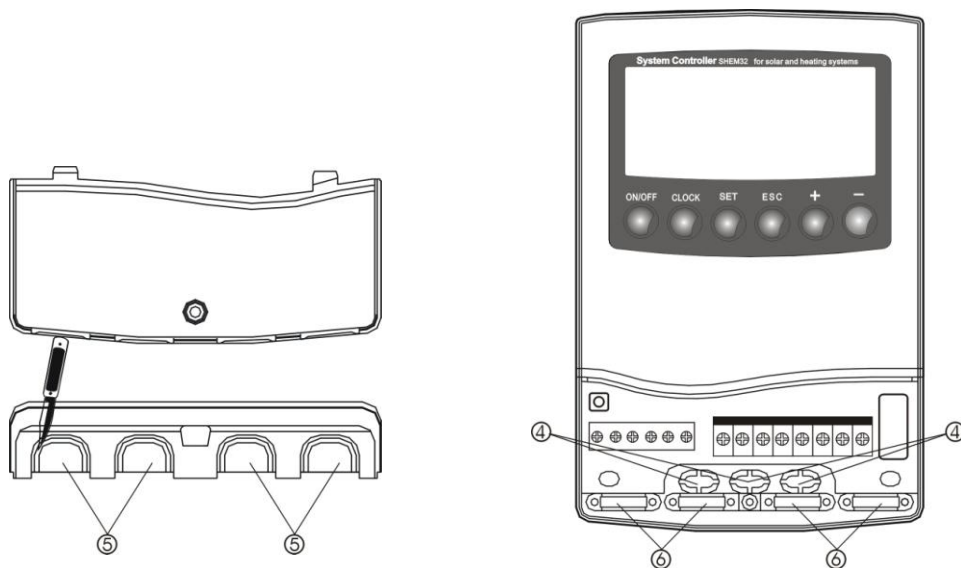

2.3 Terminal connections



Before opening the cover plate, please be sure to switch-off the power supply and pay attention to the local electric codes.

Terminal layout

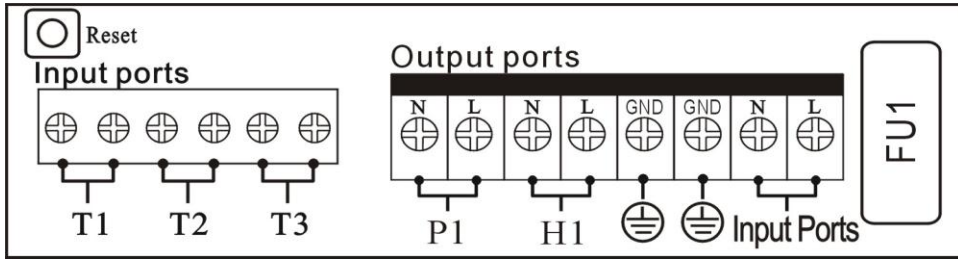

“ **Reset**” button: This button is on the terminal connection panel. If system program is not working, press “Reset” to recover the system program and the factory settings.

Power connection

Power connection terminal: Input ports

Ground terminal: GND

Output ports: P1, H1

Sensor input ports

Input sensor ports T1: for Pt1000 sensor, used for measuring the temperature of collector.

Input sensor ports T2: for NTC10K, B=3950 sensor, used for measuring the temperature of tank.

Input sensor ports T3: for NTC10K, B=3950 sensor, used for measuring the temperature of additional tank in multiple solar tank applications.

Advice regarding the installation of temperature sensors:

Only original factory equipped Pt1000 temperature sensors are approved for use with the collector, it is equipped with a 1.5meter silicon cable and suitable for all weather conditions, the temperature sensor and cable are temperature resistant up to 536°F. It is not necessary to distinguish the positive and negative polarity of the sensor connections.

Only original factory equipped NTC10K,B=3950 temperature sensors are approved for use with tanks and pipes. It is equipped with a 1.5meter PVC cable, and they are temperature resistant up to 221°F. It is not necessary to distinguish the positive and negative polarity of the sensor connection.

All sensor cables carry low voltage, and to avoid inductive effects, must not be laid close to 230 volt or 400-volt cables (minimum separation of 4 inches)

If external inductive effects exist, e.g. from heavy current cables, overhead train cables, transformer substations, radio and television devices, amateur radio stations, microwave devices etc, then the cables to the sensors must be adequately shielded.

Sensor cables may be extended to a maximum length of 330 ft. When cable's length is up to 165 ft., AWG18 wire should be used. When cable's length is up to 330 ft., AWG14 wire should be used.

Output ports

Output P1: for solar circuit pump, electromagnetic relay, and max. switching current 3.5A,

P1 ports are always open

Output H1: for multiple solar storage tank circulation pump, electromagnetic relay, and max. switching current 3.5A, H1 connection ports are always open

Fuse FU1 : power supply fuse for protection of electronics. 250V, 0.5A.

3. Commissioning

Connect the sensors and pumps to the controller before you connect the power supply! After switching on power to the controller, first set the time, password and parameters of the system. Factory settings are optimally set for the simple drainback system. They may be changed by a solar expert to be used with other systems and applications.

3.1 Set time

- ▶ Press "Clock" button, time displays on screen, hour selection area "00" blinks on display screen.
- ▶ Press "+" "-" buttons to set hour of clock
- ▶ Press "Clock" button again, minute area "00" blinks
- ▶ Press "+" "-" buttons to set minute of clock.
- ▶ Press "ESC" button

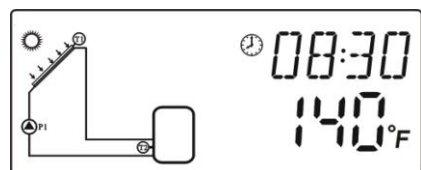

to exit set program, or wait for 20 seconds to exit program automatically.

3.2 SCH system selection

Under standby status, access the main menu to choose SCH system

▶ Press "SET" button, "PWD 0000" displays on screen, the left digit blinks, asks to enter password. (factory setting "0000")

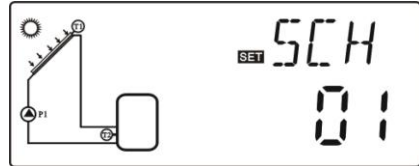

▶ Press "+" "-" buttons to enter the first digit of password.

▶ Press "SET" again, second digit blinks,

▶ Press "+" "-" buttons to enter the second digit of password

▶ Press "SET" again, the third digit blinks,

▶ Press "+" "-" buttons to enter the third digit of password

▶ Press "SET" again, the fourth digit blinks,

▶ Press "+" "-" buttons to enter the fourth digit of password

▶ Press "SET" button again, to access the main menu, "SCH 01" displays on screen.

▶ Press "SET" to enter system selection program, "01" blinks, the one tank, one pump system displays on screen

▶ Press "+" "-" buttons to select desired system. "02" blinks, the multiple tank, two pump system displays on screen. Select between the two systems.

▶ Press "ESC" to exit the program, or wait for 20 seconds to exit automatically, the new parameters are saved automatically.

3.3 Menu structure

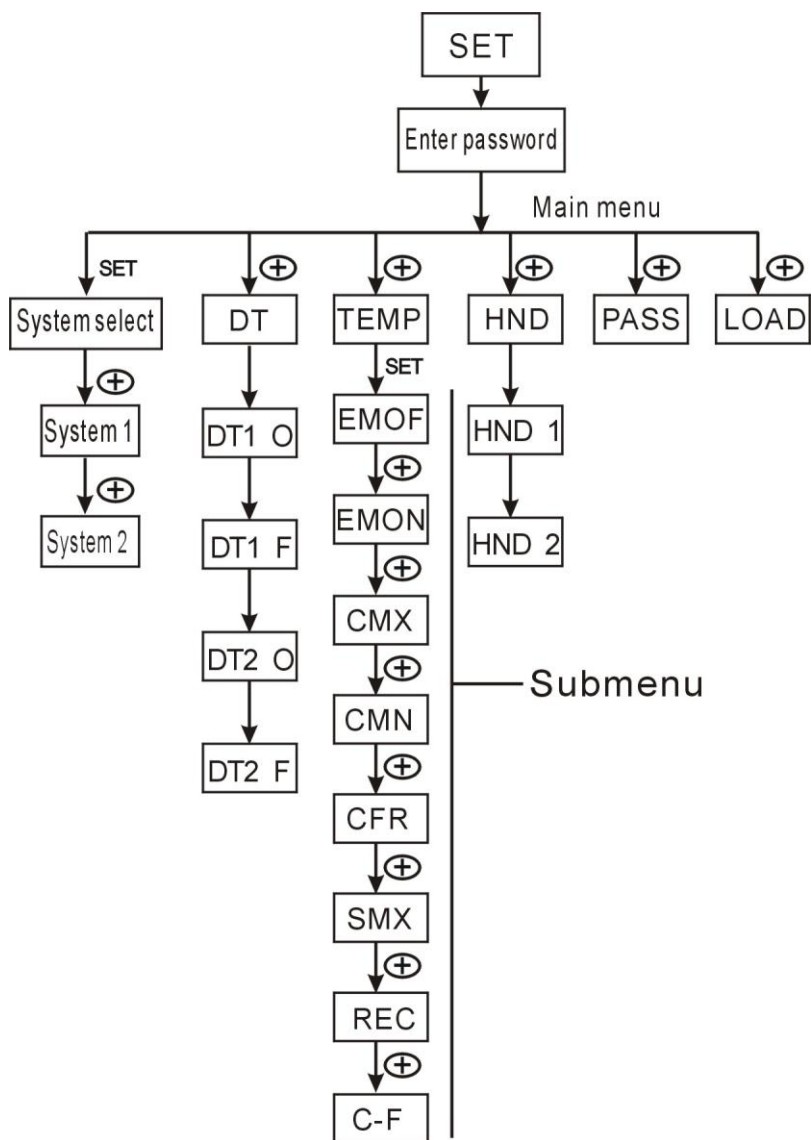

Submenu:

Through submenus, installer can set the parameters as desired values, please check them carefully.

3.4 Menu description

Code (Mainmenu)	Code (Submenu)	Menu Description
SCH		System choice
DT		temperature difference set
	DT1 O	switch-on Temp between collector(T1) and tank(T2)
	DT1 F	switch-off Temp between collector(T1) and tank(T2)
	DT2 O	switch-on Temp between tank(T2) and tank(T3)
	DT2 F	switch-off Temp between tank(T2) and tank(T3)
TEMP		Temperature
	EMOF	Maximum turn off temperature of collector
	EMON	Maximum turn on temperature of collector
	CMX	Maximum temperature of collector (Collector cooling function)
	CMN	Low temperature protection of collector
	CFR	Frost protection of collector
	SMX	Maximum temperature of tank1
	REC	Tank re-cooling function
	C-F	Celsius or Fahrenheit
HND		Manual pump controlling
	HND1	For output port P1
	HND2	For output port H1
PASS		Password set
LOAD		Recovery to factory settings

3.5 System description

3.5.1 SYSTEM1

1 collector array – 1 storage tank – 1 pump

Description:

The solar circuit pump (P1) is switched on as soon as the switch-on temperature difference (ΔT_{on}) between the collector array (T1) and the storage tank (T2) is reached. If the temperature difference between the collector array (T1) and storage tank (T2) drops below the switch-off temperature difference (ΔT_{off}), or the temperature of storage tank (T2) reaches the preset maximum storage temperature, then the solar circuit pump (P1) is switched off.

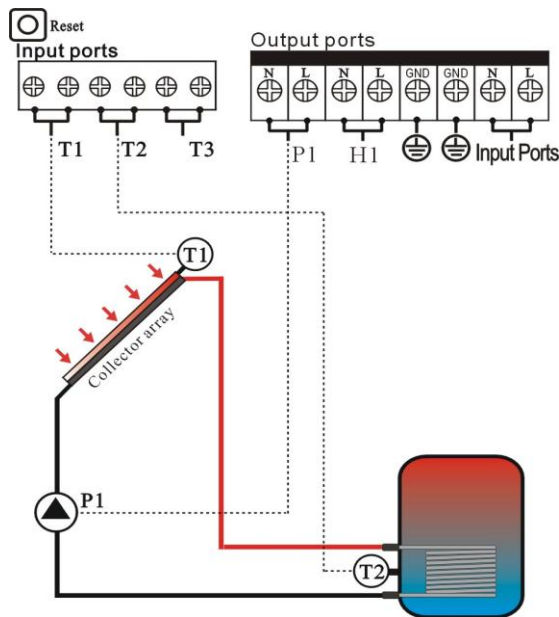

T1: Temperature sensor for collector array

T2: Temperature sensor of tank

P1: Solar circuit pump

3.5.2 SYSTEM2

1 collector array – 2 storage tanks – 2 Circuit pumps

Description:

The solar circuit pump (P1) is switched on as soon as the switch-on temperature difference (ΔT_{on}) between the collector array (T1) and the storage tank1 (T2) is reached. If the temperature difference between the collector array (T1) and storage tank1 (T2) drops below the switch-off temperature difference (ΔT_{off}), or the temperature of storage tank1 (T2) reaches the preset maximum storage temperature, then the solar circuit pump (P1) is switched off.

The circulation pump (H1) is switched on as soon as the switch-on temperature difference (ΔT_{on}) between the storage tank1 (T2) and the storage tank2 (T3) is reached. If the temperature difference between the storage tank1 (T2) and the storage tank2 (T3) drops below the switch-off temperature difference (ΔT_{off}), then the circulation pump (H1) is switched off.

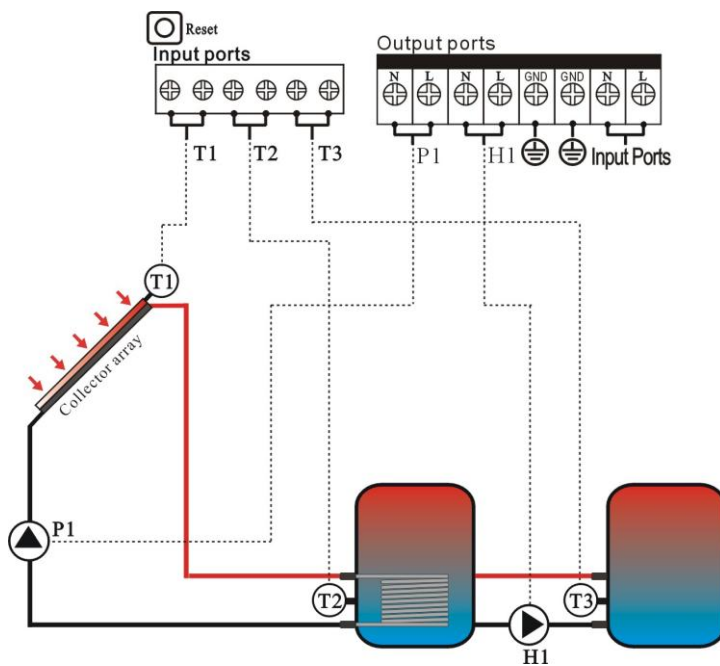

T1: Temperature sensor for collector array

T2: Temperature sensor of tank1

T3: Temperature sensor of tank2

P1: Solar circuit pump

H1: circulation pump between tank1 and tank2

4. Controller functions

4.1 Access main menu

Under standby status, doing the following will access main menu

- ▶ Press “SET” button, “PWD 0000” displays on screen. The first digit blinks, asking to enter password. Factory default password is “0000”
- ▶ Press “+”“-” buttons to enter first digit of password.
- ▶ Press “SET” button again, the second digit blinks
- ▶ Press “+”“-” buttons, to enter second digit of password
- ▶ Press “SET” button again, the third digit blinks
- ▶ Press “+”“-” buttons to enter the third digit of password
- ▶ Press “SET” button again, the fourth digit blinks
- ▶ Press “+”“-” buttons to enter the fourth digit of password
- ▶ Press “SET” button again to access main menu
- ▶ Press “+”“-” buttons to select from the main menu
- ▶ Press “ESC” button to exit main menu

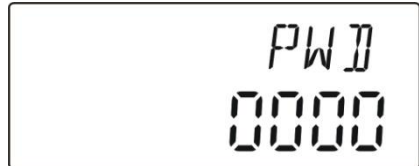

4.2 Access submenu

After selecting main menu, do the following to access submenus

- ▶ Press “SET” button, to access submenu
- ▶ Press “+”“-” buttons to select from submenu
- ▶ Press “SET” button again to access program. You can adjust parameter value now.
- ▶ Press “+”“-” buttons, to adjust the value of parameter
- ▶ Press “ESC” button, exit program of submenu
- ▶ Press “ESC” button again, to exit main menu.

4.3 Main menu DT O & DT F Temperature difference function

Description:

Solar circuit pump(P1) is triggered by the temperature difference function. When the temperature difference between collector(T1) and tank(T2) reaches the switch-on, DT1O, the solar circuit pump is triggered.

For example: the switch-on DT1O is 16°F, switch-off DT1F is 4 °F, if the temperature in

the tank is 68 °F, then just when collector temperature rises up to 84 °F, pump is triggered, and when collector temperature drops to 72 °F, pump is ceased.

Note: the switch-on/off DT of 16 °F and 4 °F are standard system settings according to many years' experience. Only in special applications does it need to be changed, (e.g far distance heat transferring). Normally it is recommend to use default settings. Switch-on and switch-off DT are alternating set. To avoid mistakes the minimum difference between two temperature differences ($\Delta T_{on} - \Delta T_{off}$) is set as 4 °F.

Setup circuit pump turnon and turnoff:

To access, go to main menu DT.

▶ Press "SET" button, to access setting program of DT 1O, "DT 1O 16 °F" displays on screen, "16 °F" blinks, the switch-on temperature difference can be set.



▶ Press "+" "-" buttons, to adjust the value of switch-on DT, adjustable range (OFF+4 °F) ~ 36 °F, factory setting is 16 °F

▶ Press "ESC" button to exit this setting, parameter is saved automatically.

▶ Press "+" button, to access setting program of DT 1F, "DT 1F 4 °F" displays on screen. Press "SET" button, "04 °F" blinks, the switch-off temperature difference can be set.



▶ Press "+" "-" buttons to adjust the value of switch-off DT, adjustable range 0 °F ~ (ON-4 °F) , factory setting is 4 °F.

▶ Press "ESC" to exit menu, or wait for 20 seconds to exit automatically, the setup parameters are saved automatically.

▶ Press "+" button, to access setting program of DT 2O, "DT 2O 4 °F" displays on screen, press "SET" button, "4 °F" blinks, the switch-on temperature difference can be set.



▶ Press "+" "-" buttons, to adjust the value of switch-on DT, adjustable range (OFF+4 °F) ~ 36 °F, factory setting is 4 °F

▶ Press "ESC" button to exit this setting, parameter is saved automatically.

▶ Press “+” button, to access setting program of DT 2F, “DT 2F 1 °F” displays on screen, press “SET” button, “1 °F” blinks, the switch-off temperature difference can be set.



▶ Press “+” “-” buttons to adjust the value of switch-off DT, adjustable range 0 °F~ (ON-4 °F) , factory setting is 1 °F.

▶ Press “ESC” to exit menu, or wait for 20 seconds to exit automatically, the setup parameters are saved automatically.

4.4 TEMP Temperature main menu

For every controller, the factory set parameters are optimally set for simple drainback systems. But these parameters can also be set individually for other system requirements. Please carefully observe the operation of system components after setting.

Note: parameters that can be set depend on the selected system, not all the parameters can be adjusted in a solar system.

The following submenus can be accessed though TEMP main menu.

EM Emergency switch-off temperature of collector-----	4.4.1
CMX Maximum limited collector temperature (collector cooling function) -----	4.4.2
CMN low temperature protection of collector -----	4.4.3
CFR frost protection of collector -----	4.4.4
SMX Maximum temperature of tank-----	4.4.5
REC Tank re-cooling function -----	4.4.6
C-F Celsius and Fahrenheit temperature transferring-----	4.4.9

Function	Adjustable range	Factory set
EMOF Maximum turnoff temperature of collector	(ON+146 °F)~392 °F	195 °F
EMON Maximum turnon temperature of collector	(OFF-140 °F)~386 °F	190 °F
CMX Maximum limited collector temperature (collector cooling function)	140 °F~392 °F	---
CMN low temperature protection of collector	32 °F~194 °F	50 °F
CFR frost protection of collector	14 °F~50 °F	---
SMX Maximum temperature of tank	35 °F~203 °F	170 °F
REC Tank re-cooling function		OFF
C-F Celsius or Fahrenheit	°C ~ °F	°F

4.4.1 EM Emergency collector temperature(Emergency switch-off temperature of collector)

When collector temperature reaches the limited temperature (EM), this function is activated. The solar circulation pump is stopped in order to avoid damage to other system components caused by high temperature. **EMOF**, emergency turnoff temperature of collector (factory setting is 195 °F). When the temperature of collector rises up to EMOF limited temperature, solar circuit pump is ceased, but when collector temperature drops to EMON(factory set is 190 °F), solar circuit pump restarts, and this function is deactivated.

EMOF Emergency turn off temperature of collector

To access, go to main menu TEMP, then select submenu EMOF(Emergency turn off temperature of collector),"EMOF 195 °F " displays on screen.

▶ Press"SET"button,"195 °F " displays on screen and blinks.

▶ Press"+" "-"buttons to adjust the value of max switch off. Adjustable range(ON+146 °F)~392 °F,factory setting is 195 °F.

▶ Press"SET"button to deactivate or activate the function,when deactivated, "EMOF---" displays

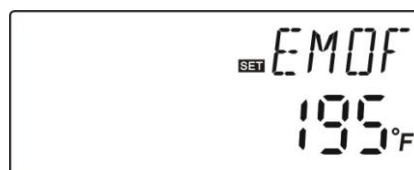

▶ Press “ESC” button to exit this setting, parameter is saved automatically.

EMON Emergency turn on temperature of collector

To access, go to main menu TEMP, then select submenu EMON(Emergency turn on temperature of collector),"EMON 190 °F " displays on screen.



▶ Press"SET"button,"190 °F" displays on screen and blinks.

▶ Press"+" "-"buttons to adjust the value of max.switch-on, adjustable range(OFF-140 °F)~386 °F, factory setting is 190 °F.

▶ Press"SET"button to deactivate or activate the function, when deactivated, "EMON--" displays

▶ Press “ESC” button to exit this setting, parameter is saved automatically.



  This display means that the EMOF is activated, (the tank temperature reached max value).



 This display means that the EMOF is activated, (the tank temperature has not reached max value)

4.4.2 CMX Maximum limited collector temperature (collector cooling function)

Function description:

The collector cooling function delays the vaporization of the heat transfer fluid in pressurized systems. Shortly before reaching the maximum temperature of the collector, the solar pump starts working in order to cool down the heat transfer fluid in the collectors using the heat losses occurring in pipelines and storage tank.

When tank temperature rises to its preset maximum temperature(SMX), solar circuit pump is ceased automatically even when the temperature difference is satisfied. If the sunshine is very good, the collector temperature will continue to rise. When collector temperature rises up to its maximum temperature(CMX), solar pump will be triggered again even if the tank temperature is already achieved. The solar pump works until the collector temperature drops from the circulation or when tank temperature rises to it's emergency temperature 203 °F).

When  displays, and  blinks on the screen, it indicates that tank emergency temperature has been reached.The tank emergency temperature is ≥ 203 °F

Setup steps:

To access, go to main menu TEMP, then select submenu CMX “CMX ---” displays on screen

▶ Press “SET” button, parameter “231 °F” blinks.

▶ Press “+”“-” buttons, to adjust the collector protection temperature, adjustable range (140 °F~392 °F)

▶ Repress “SET” button, activate and deactivate this function. When deactivated, “CMX - - -” displays on screen.

▶ Press “ESC” button to exit the menu or wait for 20 seconds to exit automatically, parameters are saved automatically.



When CMX signal displays on screen, it indicates that this function is activated.

4.4.3 CMN low temperature protection of collector

Description:

When the temperature of collector is below preset CMN temperature, solar circuit pump is ceased, even when the temperature difference between collector and tank exceeds switch-on temperature difference, so the solar pump won't work. When temperature of collector is 5 °F higher than the preset CMN temperature, solar circuit pump is restarted and controller exits this program.

Setup steps:

To access, go to main menu TEMP, then select submenu CMN, “CMN 50 °F” displays on screen, default set is 50 °F.

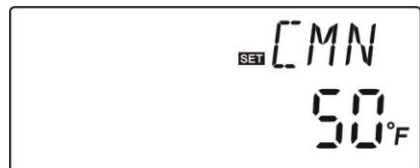

▶ Press “SET” button, default “50 °F” blinks on screen.

▶ Repress “SET” button, to deactivate and activate this function. When deactivated, "CMN---" displays on screen.

▶ Press “+”“-” buttons, to adjust the low protection temperature of collector, CMN. The adjustable range (32 °F~194 °F).

▶ Press “ESC” button to exit the menu or wait for 20 seconds to exit automatically, parameters are saved automatically.



When CMN signal displays on screen, it indicates that this function is activated.

4.4.4 CFR frost protection of collector

Description:

During winter when the temperature of collector is below the preset frost protection temperature (factory setting is 39 °F), solar circuit pump is triggered, except when tank temperature (T2) is 39 °F or below. When collector heats up to 44 °F, solar circuit pump is ceased, and the program of CFR exits automatically.

This function is used in pressurized systems which use water as the heat transfer fluid in temperate climates that rarely see freezing temperatures.

Setup steps:

To access, go to main menu TEMP, then select submenu CFR, “CFR ----” displays on screen, default setting is off.

- ▶ Press “SET” button, default off “- - -” blinks.
- ▶ Repress “SET” button, to activate or deactivate this function
- ▶ Press “+”“-” buttons, to adjust the frost protection function, adjustable range is (14 °F~50 °F)
- ▶ Press “ESC” button to exit the menu or wait for 20 seconds to exit automatically, parameters are saved automatically.



When CFR signal displays on screen, it indicates that this function is activated.

Note: this function is only needed for pressurized solar systems which use no-anti-freezing liquid; this kind of system is only suitable in areas where the ambient temperature is near 32 °F only a few days a year. If safety requirement is very high, then anti-freeze is necessary, we suggest using propylene glycol to avoid freeze problems.

4.4.5 SMX Maximum temperature of tank

Description:

When the DT between collector T1 and Tank T2 meets the switch-on DT10 of circulation, solar pump is triggered, but in order to avoid too high temperature inside tank, controller will check whether the temperature (T2) of tank is higher than maximum temperature of tank, when T2 is higher than preset SMX temperature, solar pump is ceased even in the case that DT meets condition. When tank temperature

drops and is 4 °F below the SMX, solar pump restarts when DT1O meets condition.

Setup steps:

To access, go to main menu TEMP, then select submenu SMX, “SMX 170 °F” displays on screen.

- ▶ Press “SET” button, parameter “170 °F”blinks
- ▶ Press “+”“—” buttons to adjust the value of maximum temperature of tank1. Adjustable range is (35 °F~203 °F) , default set is 170 °F



- ▶ Reprress “SET” button to activate and deactivate this function, if function is deactivated, “SMX - - -” displays on the screen.
- ▶ Press “ESC” button to exit the menu or wait for 20 seconds to exit automatically, parameters are saved automatically.



When SMX signal displays on screen, it indicates that this function is activated.

4.4.6 REC Tank re-cooling function

Description:

If tank temperature is over tank’s maximum temperature, and at the same time, collector temperature is 8 °F lower than tank temperature, then solar pump is triggered. Through this reversed circulation, the tank temperature is reduced by heat loss occurring in the collectors. Solar pump keeps working until tank temperature drops below its maximum temperature.

Setup steps:

To access, go to main menu TEMP, then select submenu REC, “REC OFF” displays on screen, default setting is off.

- ▶ Press “SET” button, parameter “OFF” blinks on screen
- ▶ Reprress “SET” button to activate or deactivate this function, after function is activated, display is now “REC ON”



- ▶ Press “ESC” button to exit the menu or wait for 20 seconds to exit automatically, parameters are saved automatically.



When REC signal displays on screen, it indicates that this function is activated.

4.4.7 C- F Celsius or Fahrenheit

Setup steps:

To access, go to main menu TEMP, then select submenu C-F, "C_F °F" displays on screen.

▶ Press "SET" button, parameter "°F" blinks on the screen.

▶ Press "+" button, to select between Celsius and Fahrenheit temperature, factory set is °F

▶ Press "ESC" button to exit menu or wait for 20 seconds to exit automatically, parameters are saved automatically.



4.5 HND Manual Pump mode

When using this controller for the first time or when debugging this controller, outputs of this controller (P1,H1) can be triggered manually.

Setup steps:

To access, go to main menu HND,

▶ Press "SET" button, "HND1 off" displays on the screen, P1 output manually set

▶ Repress "SET" button, "HND1 on" displays on the screen, P1 output is switched-on

▶ Repress "SET" again, "HND1 off" displays, P1 output is switched-off

▶ Press "ESC" to exit P1 set program



▶ Press "+" button, "HND2 off" displays on the screen, H1 output manually set

▶ Press "SET" button, "HND2 on" displays on the screen, H1 output is switched-on

▶ Repress "SET" again, "HND2 off" displays, H1 output is switched-off

▶ Press "ESC" to exit H1 set program



Note: when manual mode is  activated, signal displays on the screen, after 15 minutes all outputs are switched-off, controller exits manual mode automatically.

4.6 PASS Password setting

Setup steps:

To access, go to main menu PASS,

▶ Press “SET” button, “PWDC 0000”, the left digit blinks, asking to enter the password, factory set is “0000”

▶ Press “+”“-” buttons to enter the first digit

▶ Repress “SET” button, the second digit blinks

▶ Press “+”“-” buttons to enter the second digit

▶ Repress “SET” button, the third digit blinks

▶ Press “+”“-” buttons to enter the third digit

▶ Repress “SET” button, the fourth digit blinks

▶ Press “+”“-” buttons to enter the fourth digit

▶ Press “SET” button, “PWDN 0000” displays on the screen, asking to enter a new password.

Repeat steps above to enter a new password

▶ Press “SET” button, “PWDG 0000” displays on the screen, asking to reenter the new password.

Repeat steps above to reenter the new password, “PWOK” displays on the screen to indicate reentering password was successful.

▶ Press “ESC” button to exit set program or wait for 20 seconds to exit automatically.



Warning!

If the password is forgotten, it is not possible to recover, but you can recover the factory settings, then you can reenter a new password with the steps described above. Do the following to recover the factory settings.

▶ Open the cover plate.

▶ Press “-” and hold down, then repress the reset button, which is on the terminal plate.

▶ Buzzer makes “du-----” 3 times, then release “-” button. Controller recovers the factory settings, a new password can now be set. Reminder: If the controller's factory settings were changed when the system was installed, the settings will need to be changed again.



4.7 LOAD Recover factory settings

Setup steps:

To access, go to main menu REST,

▶ Press “SET” button, “YES” displays on the screen.

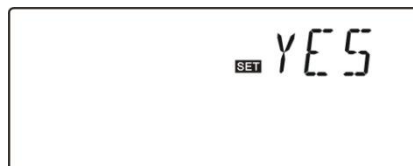

▶ Hold down “SET” button, buzzer makes “du-----

“ 3 times, then release “SET” button. Controller recovers the factory settings, new parameters can be reset now.

▶ Press “ESC” button to exit set program or wait for 20 seconds to exit automatically.

4.8 Temperature query function

Under standby status,

▶ Press “+”“-” buttons to check the readings of temperature sensors T1~ T3.

When checking temperature, T1 – T3 will display one by one. The corresponding sensor signal blinks on the display.

▶ Press “ESC” button, clock and tank temperature can be displayed.

4.9 ON/OFF function

Under standby status,

▶ Press "ON/OFF" button, the controller turns off

▶ Press "ON/OFF" button, the controller turns on and goes into standby status

5. Protection function

5.1. Memory protection

In case power failure occurs, controller keeps the parameter settings unchanged.

5.2 Screen protection

When no buttons are pressed for 3 minutes, screen protection is activated automatically, and the LCD lighting lamp is switched-off. Press any button to light LCD lamp again.

6. Troubleshooting

6.1 Protection



When there is a break or short circuit between the connection of temperature sensors, the controller switches off the corresponding functions and no more output signals are given. At the same time, error signals  appear on the display. If the controller does not work correctly, please check following points.

► Press “+”“-” buttons to check error code,  signal displays on the LCD screen

Error message on LCD screen	Meaning	Cause of error	Error rectification
T1 - - -	T1 sensor problem	Sensor wiring interrupted, not connected or short circuit	Check resistance value, replace
T2 - - -	T2 sensor problem	Sensor wiring interrupted, not connected or short circuit	Check resistance value, replace
T3 - - -	T3 sensor problem	Sensor wiring interrupted, not connected or short circuit	Check resistance value, replace

6.2 Trouble checking

This controller is a quality product, conceived for years of continuous trouble-free operation. If a problem occurs, the cause of the problem very often lies not in the controller, but in the peripheral components. The following description of some well-known problems should help the installer and operator to isolate the problem, so that the system can be place back into operation as quickly as possible and to avoid unnecessary costs. Of course, not all possible problems can be listed here. However, most of the normal problems encountered with the controller can be found in the list below, only return the controller to seller when you are absolutely sure that none of the problems listed below is responsible for the fault.

Symptoms	Secondary symptoms	Possible cause	Procedure
Controller does not appear to function at all	Display shows nothing, no display illumination	Controller power supply is interrupted or program is out of work or Blown fuse	Check the controller power cable Press reset button or replace the fuse
The solar pump doesn't operate, despite the fact that switch-on conditions are satisfied	The pump symbol in the display blinks	Pump power supply is interrupted	Check the pump power cable
Pump doesn't operate	The pump symbol in the display doesn't blink.  Lighted or  blinks	The maximum storage tank temperature (SMX) has been reached The maximum collector temperature (EM) has been reached.	No fault
	 displays on the screen	Fault (short circuit or open circuit) in a temperature sensor	On the controller, request the current values from all connected temperature sensors, replace all defective sensors and /or cabling.
The solar pumps operated, despite the fact that the switch-on conditions are not satisfied.	The pump symbol in the display blinks.	Frost protection function or tank re-cooling function is activated.	No problem, it is normal. If necessary, deactivate the corresponding functions.



Warning! Remove the device from the main electric supply before opening the cover plate. A potentially defective sensor can be checked using an ohmmeter. To

do this, the sensor must be disconnected, its resistance measured, and the value compared with the figures in the table below, small deviation ($\pm 1\%$) is acceptable,

PT1000 resistance value

°F	32	50	68	86	104	122	140	158	176	194	212
Ω	1000	1039	1077	1116	1155	1194	1232	1270	1309	1347	1385

NTC 10K B=3950 resistance value

°F	32	50	68	86	104	122	140	158	176	194	212
Ω	33620	20174	12535	8037	5301	3588	2486	1759	1270	933	697

7. Quality Guarantee

Manufacturer provides following quality responsibilities to end-users: within the period of the warranty, the manufacturer guarantees that any failure is not caused by the manufacturing process or materials selection. A correct installation will not lead to failure. When a controller is handled incorrectly or crudely, installed incorrectly, operated improperly, or the sensors are connected improperly, the warranty is invalidated.

The warranty expires 24 months after the date of purchasing the controller.

8. Technical data

Type Specification	Technical Data
Dimensions	7in x 4.7in x 1.7in
Power supply	AC110V±10%
Power consumption	< 3W
Accuracy of temperature measuring	±4°F
Range of collector temperature measuring	-14°F ~ 428°F
Range of tank temperature measuring	32°F ~ 230°F
Circuit pumps	2pcs, ≤ 600W
Inputs	1 x Pt1000 sensor (silicon cable≤ 536°F) 2 x NTC10K, B=3950sensor (pvc cable≤ 221°F)
Outputs	2 relays, for circulation pumps, power: ≤ 600W Ambient temperature
	-14°F ~ 122°F
Water proof grade	IP40

9. Parts List

Type Lists	Quantity
Controller	1
Operation manual	1
PT1000 sensor (size: φ6*50mm,cable length1.5m)	1
NTC10K (size: φ6*50mm,cable length1.5m)	2
Plastic expansion screw	3
Mounting Screw	3
Strain-relief clamp	4
Power cord(with 1.5meter cable)	1

10. Accessories for this controller

Sensor for collector: high accuracy PT1000 sensor(SB1.5)
Parameters: PT1000, $\phi 6 \times 50 \text{mm} \times 1.5 \text{m}$

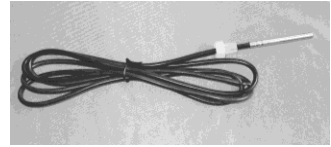

Sensor for tank: high accuracy NTC 10K sensor (SG1.5)
Parameters: NTC10K, $B=3950$, $\phi 6 \times 50 \text{mm} \times 1.5 \text{m}$

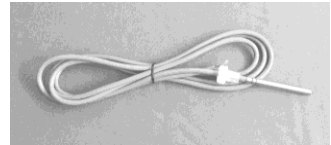

Thermowell for sensor: stainless thermowell (sp1)
Parameters: 1/2" male thread, $\phi 8 \times 200 \text{mm}$.

(Not included with controller)

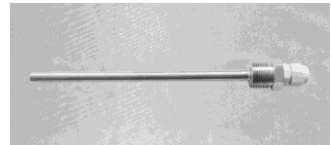

Operation manual of solar water controller SHEM32

PAGE

- PAGE * MERGEFORMAT 29 -